



**AEROMOTIVE**  
**Part # 17130**  
**86-95 Mustang 5.0L Fuel System Kit**  
**INSTALLATION INSTRUCTIONS**

**CAUTION:**

Installation of this product requires detailed knowledge of automotive systems and repair procedures. We recommend that this installation be carried out by a qualified automotive technician.

Installation of this product requires handling of gasoline. Ensure you are working in a well ventilated area with an approved fire extinguisher nearby. Extinguish all open flames, prohibit smoking and eliminate all sources of ignition in the area of the vehicle before proceeding with the installation.

When installing this product, wear eye goggles and other safety apparel as needed to protect yourself from debris and sprayed gasoline.

**WARNING!**

The fuel system is under pressure. Do not open the fuel system until the pressure has been relieved. Refer to the appropriate vehicle service manual for the procedure and precautions for relieving the fuel system pressure.

Aeromotive system components are not legal for sale or use on emission controlled motor vehicles.

**This kit contains the following parts:**

- |  |   |
|--|---|
| 1 ea P/N 18690 Cobra-Top Stealth Fuel Tank | 1 ea P/N 13109 A1000-06 Fuel Pressure Regulator |
| 1 ea P/N 18679 A1000 Stealth Fuel Pump     | 1 ea P/N 14101 Ford 5.0L Billet Fuel Rails      |
| 1 ea P/N 16301 fuel pump wiring kit        | 1 ea P/N 15673 AN-08 to 2-AN-06 Y-block         |
| 1 ea 3ft length of 10-ga. Black wire       | 2 ea ¼" flat washers                            |
| 1 ea 25ft length of 10-ga. Red wire        | 2 ea ¼-20 nyloc nuts                            |
| 1 ea 30-amp circuit breaker                | 2 ea ¼-20 x 1" carriage bolts                   |
| 1 ea 30-amp automotive relay               | 12 ea tie-wraps                                 |
| 2 ea blue female blade connector           | 3 ea AN-06 o-ring                               |
| 2 ea yellow female blade connector         | 6 ea AN-08 o-ring                               |
| 5 ea yellow #10 stud ring connector        | 2 ea AN-10 o-ring                               |
| 1 ea yellow 3/8" stud ring connector       | 1 ea P/N 15602 AN-06 male/male flare union      |
| 6 ea tie-wraps                             | 5 ea P/N 15605 ORB-08 to AN-06 male flare       |
| 26 ft AN-06 stainless steel braided line   | 3 ea P/N 15606 ORB-06 to AN-06 male flare       |
| 16 ft AN-08 stainless steel braided line   | 1 ea P/N 15607 ORB-08 to AN-08 male flare       |
| 6 ea P/N 15650 AN-06 straight hose-end     | 2 ea P/N 15610 ORB-10 to AN-08 male flare       |
| 1 ea P/N 15651 AN-06 45-degree hose-end    | 12 ea cushioned clamps                          |
| 5 ea P/N 15652 AN-06 90-degree hose-end    | 12 ea self drilling screws                      |
| 2 ea P/N 15653 AN-08 straight hose-end     | 1 ea P/N 12305 2" billet filter bracket         |
| 2 ea P/N 15655 AN-08 90-degree hose-end    | 1 ea P/N 15633 0-100psi fuel pressure gauge     |
| 1 ea P/N 12301 Filter 10-Micron Paper      |   |

Maximum continuous operating pressure should not exceed 70 psi.

**The following steps are typical of most installations:**

Section 1 - Fuel Tank Installation / Electrical wiring

Section 2 – Fuel Rail Installation

Section 3 – Fuel Regulator Installation and Fuel Line Plumbing

Section 4 – Fuel Line Hose End Installation

Section 5 – Final Checks and System Start-up

**Typical hose end to fitting connection:**

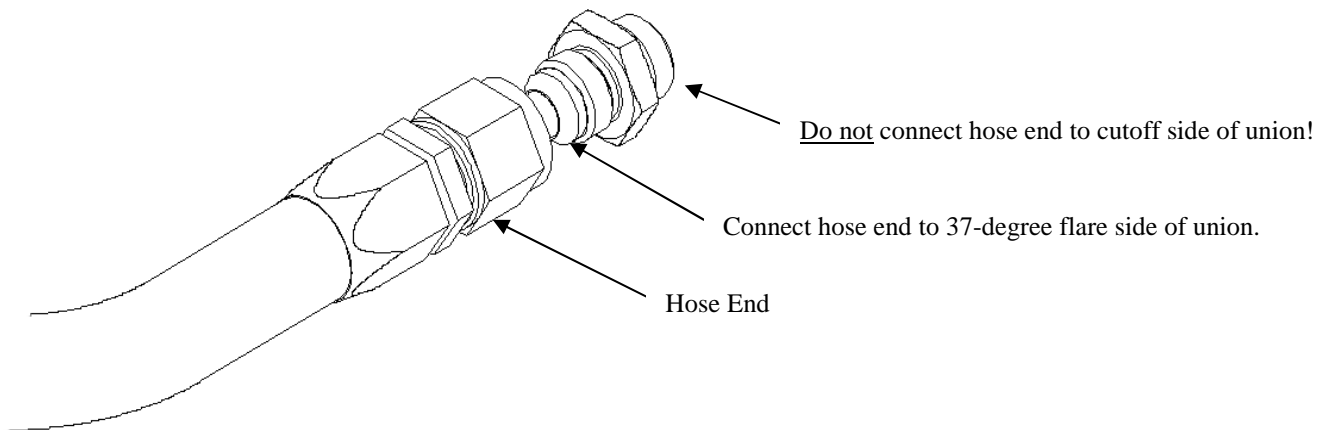

**Typical o-ring sealed port connection:**

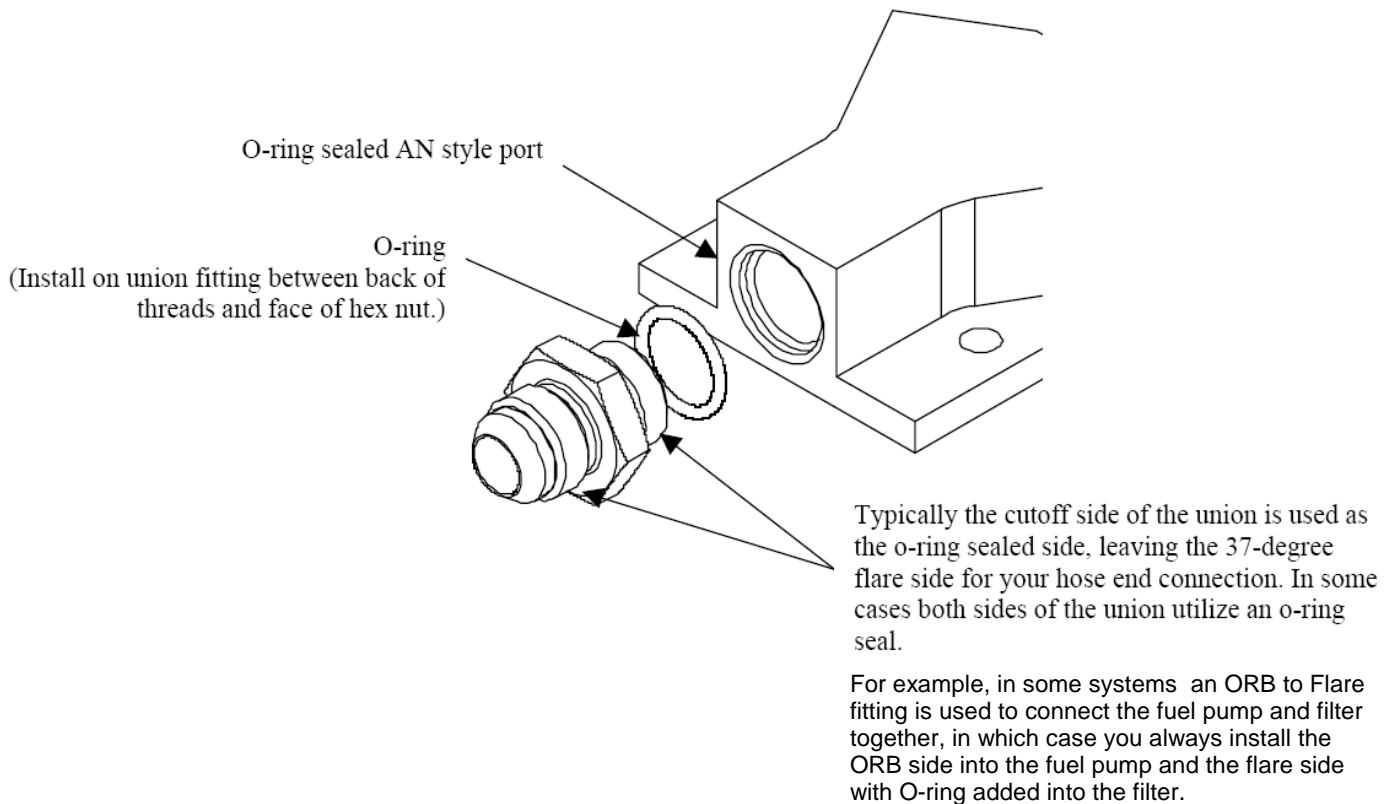

## Section 1 - Fuel Tank Installation:

- 1-1. Once the engine has been allowed to cool, disconnect the negative battery cable and relieve the fuel system pressure.
- 1-2. Raise the vehicle and support it with jack stands.
- 1-3. Referring to the appropriate vehicle service manual for instructions, drain, disconnect any electrical and fuel component connections and remove the OEM fuel tank. The removal of the vehicles exhaust system may be necessary for fuel tank removal.
- 1-4. Once the OEM fuel tank has been removed, remove the plastic fuel tank shield from the bottom of the tank. Before transferring the shield to the new Aeromotive tank, attach the 12305 filter bracket to the front side of the shield with the two supplied carriage bolts, nuts and washers (bracket will be placed facing the rear differential cover) **FIGURE 1-1**. Insert the 12301 filter into the bracket and tighten the socket head cap screw to secure the filter. Screw the two 15610 fittings with o-rings on the ORB-10 port side into each end of the filter.

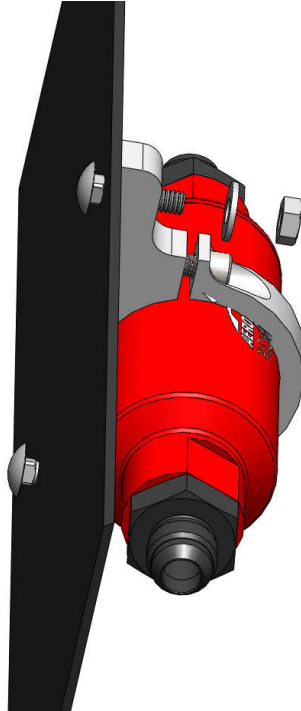

**FIGURE 1-1**

- 1-5. Remove the Aeromotive fuel pump assembly to gain access to the inside of the tank. Set fuel pump assembly to the side for later use.
- 1-6. From the old OEM fuel tank, remove the filler neck rubber grommet, fuel level sender, vent and vent grommet, and wiring harness. Inspect all parts for damage, if none found, reinstall in the new Aeromotive tank. If any of the OEM components are damaged replacement parts are available through your local Ford dealer or auto parts store. Use **FIGURE 1-2** to install the factory fuel level sender onto the provided fuel level bracket.

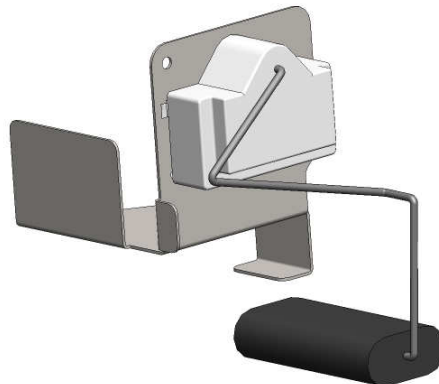

**FIGURE 1-2**

1-7. Before placing the fuel level sender assembly in the tank, attach the two level sending unit wires on the Stealth pump to the fuel level sender assembly. Using the red solder/splice and a heat gun or small butane torch, connect and solder/shrink wrap one of the wires from the fuel pump to the wire on the sending unit itself and mark the corresponding terminal on the outside of the pump with a black marker or masking tape. Next, crimp the provided ring connector on the remaining wire and attach the ring connector to the bracket with the self-tapping screw. See **FIGURE 1-3**

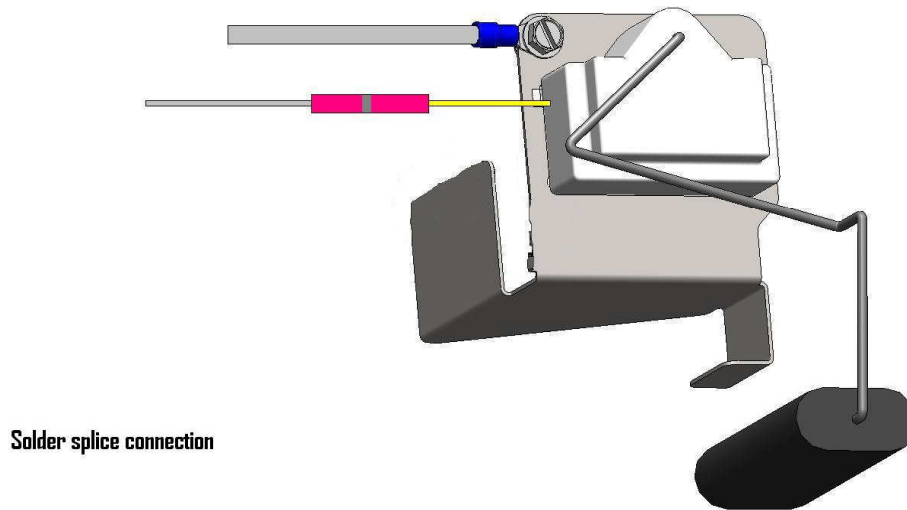

**FIGURE 1-3**

1-8. With the pump resting on top of the fuel tank, position the fuel level sender assembly into the tank as shown in **FIGURE 1-4** With the fuel level sender bracket and the baffle walls butted up against each other. Push the provided edge clips into position to secure the fuel level sending unit bracket to the top of the baffle inlet wall.

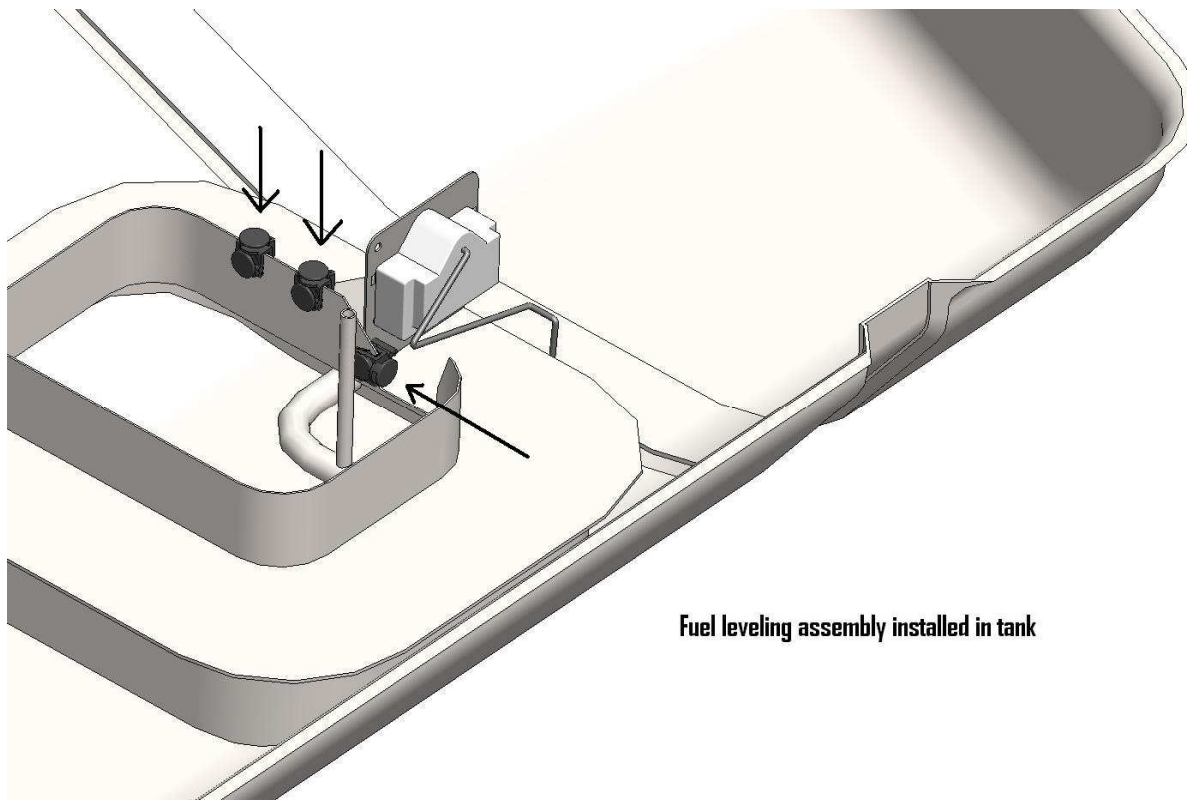

**FIGURE 1-4**

- 1-9. Now the fuel tank is ready for your Aeromotive fuel pump assembly. Place one 15607 fitting with o-ring into the outlet port and one 15605 fitting with o-ring in the return port at this time.
- 1-10. Place the fuel pump sealing gasket on top of the tank mounting ring and position the fuel pump in the tank with the outlet/return ports facing forward (toward the front of the car). Use the supplied 6 bolts and washers to secure the pump assembly to the tank. Place the lower tank shield onto the bottom of the new Aeromotive tank at this time. Assemble a small section of AN-08 hose with straight hose-end on one side and 90-degree hose-end on the other. Route from the pump outlet to the fuel filter inlet. Next, assemble a 1-2 foot section of AN-06 line with straight hose-ends at each end. Connect one end of the AN-06 line to the return port of the pump. **FIGURE 1-5**

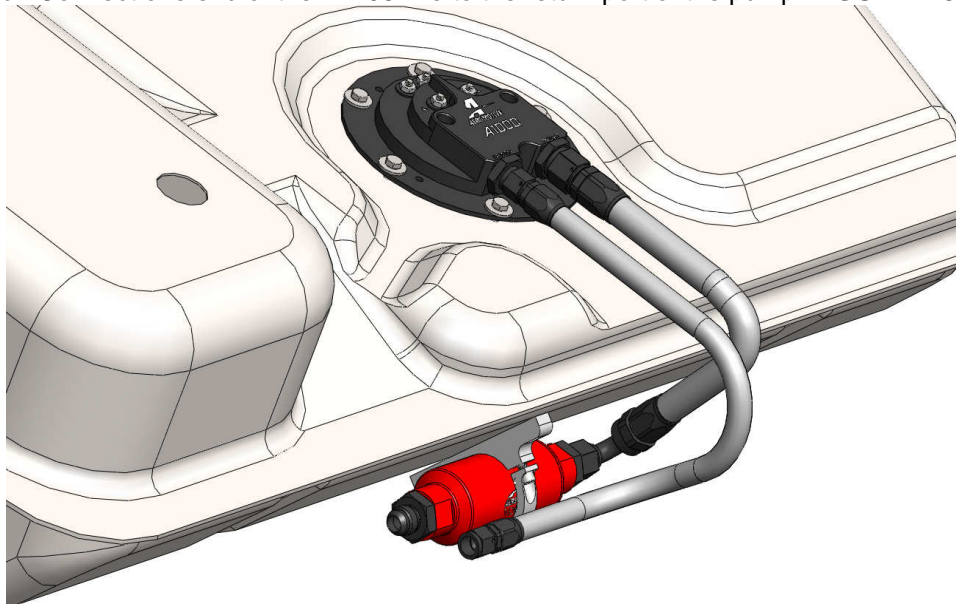

**FIGURE 1-5**

- 1-11. Before placing the fuel tank back in the car, install the small ring terminals provided onto the 10-gauge black and red wires and connect them to the Stealth Pump (+) power and (-) ground terminals. Note: Hold the ring terminal/wire firmly while tightening the terminal nuts and do not over tighten to avoid over- rotating the electrical bulkheads.
- 1-12. At this time, locate the factory fuel tank wiring harness underneath the trunk floor and, measuring 1-2 inches back from the plug, cut the 4 wires and remove the plug. Redirect the two wires formerly connected to the OEM pump, to the new fuel pump relay (provided). Install the small ring terminals provided on the remaining two wires and prepare them for connection to the fuel level sending unit terminals on the Stealth Fuel Pump.
- 1-13. Find a suitable place to mount the provided, heavy duty fuel pump relay, it is typically mounted near the end of the fuel tank harness, where the factory plug was removed in step 11-12 above. **(Never mount the relay inside of the fuel tank or next to fuel tank vents!).** Insure the new relay and any associated parts are clear of the exhaust, any moving suspension or drivetrain components and any possible road obstructions or debris.
- 1-14. Attach the OEM fuel pump wires (These typically are the red and black wires from the OEM wiring harness going to the fuel tank) to relay terminals 85 and 86 using the supplied blue female blade connectors (See Figure 1-6 Below).

**Note: Be sure to route all electrical wires clear of any moving suspension or drivetrain components, and any exhaust components! Protect wires from abrasion and road obstructions or debris.**

- 1-15. Find a suitable location for mounting the supplied 25-amp circuit breaker. For optimal circuit protection, the circuit breaker needs to be mounted as close to the supply point, either the battery or alternator charging stud, as possible.
- 1-16. Route the supplied 10-ga red wire from the circuit breaker near the battery to the relay and terminate it with one of the yellow, female blade connectors supplied. Connect it to terminal number 30 on the relay. At the circuit breaker end of this wire install one of the yellow #10 ring connectors and install it one of the two studs on the circuit breaker.

**Note: Be sure to route all electrical wires clear of any moving suspension or drivetrain components and any exhaust components! Protect wires from abrasion and road obstructions or debris.**

- 1-17. Locate the 10-gauge red wire connected to the pump in step 1-11 and route it to the new fuel pump relay in a manner that protects it from existing exhaust and suspension components.
- 1-18. Cut the red 10-gauge wire from the fuel pump to the proper length to reach the relay and terminate it with the yellow female spade connector provided. Then, connect the red wire to terminal number 87 on the relay.
- 1-19. Locate and route the black 10-gauge wire from the fuel pump to a good ground. Use the battery ground post, the chassis end of the battery ground cable, or a solid, clean chassis ground on the frame (not to sheet metal). Cut the black 10-gauge wire from the fuel pump long enough to reach the chosen ground point and install the appropriate yellow ring connector. Now connect the fuel pump ground wire securely to the grounding point.
- 1-20. Route the 10-gauge red wire provided from the chosen 12VDC supply point chosen in step 1-15. Connect 12VDC from the battery (+) post or the alternator charging stud to the remaining stud on the circuit breaker using the supplied 10-ga red wire with one of the yellow #10 ring connectors on the circuit breaker end and the yellow 3/8" ring connector on the battery or alternator end.
- 1-21. Ensure that electrical components and wires are connected properly (See **FIGURE 1-6**) and are clear of any moving suspension or drivetrain components and any exhaust components! **IMPORTANT:** Route wires carefully to protect them from damage due to abrasion and road obstructions or debris.

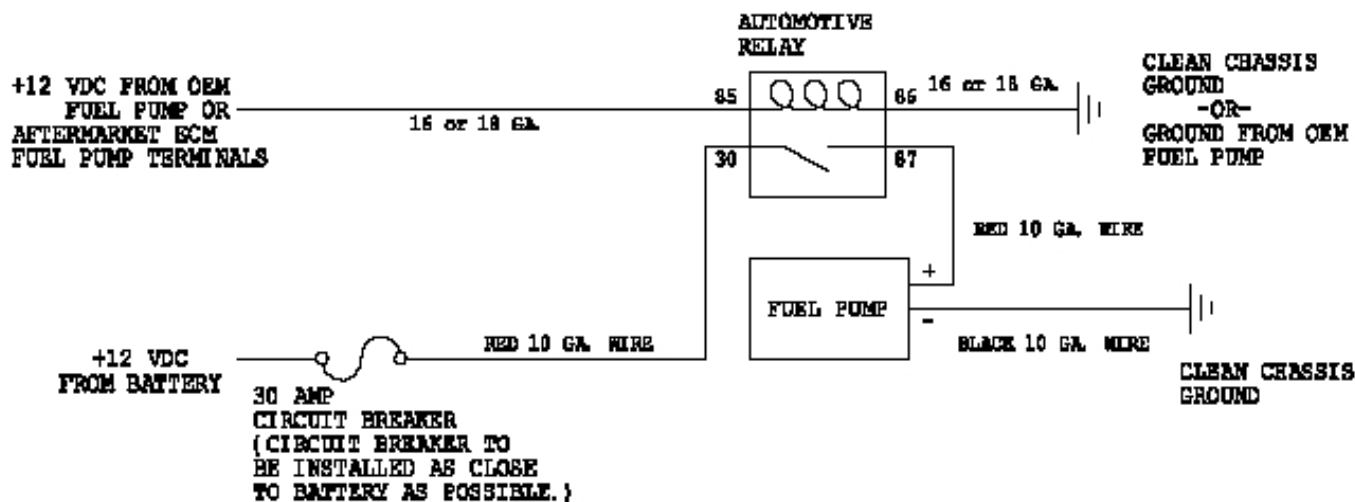

**FIGURE 1-6**

- 1-22. Position the new Aeromotive Stealth Tank under the rear of the car and connect the fuel level sending unit wires to the terminal studs on the top hat.
- 1-23. With the fuel tank in position, align the tank mounting straps and lift the tank into position, ensuring that none of the fuel lines or wiring will be pinched between the tank and the underside of the trunk, install and tighten the strap bolts.
- 1-24. Make any line or electrical wire routing adjustments necessary to clear the vehicles exhaust, suspension, and drivetrain components.

## Section 2 – Fuel Rail Installation

**Note:** Please note, due to the wide range of applications and varying OEM and after market component tolerances it has been found in a few isolated cases where it is necessary to install a 3/8" thick spacer between the upper and lower intake manifolds. This will allow you to gain clearance between the top of the fuel rails and the bottom of the upper intake manifold. These spacers are readily available from your local speed shop or mail order warehouse. Also, 94-95 Mustang 5.0L engines have extremely tight clearance between the fuel rail and distributor and may require the use of an aftermarket distributor such as MSD 8455 to allow clearance for larger, high-flow fuel rails.

- 2-1. In the vehicle's engine compartment, locate a suitable mounting location for the supplied fuel pressure regulator.
  - 2-2. Starting from the decided regulator mounting location in the engine compartment, plan a route to run an AN-08 return line back to the short return hose hooked to the fuel pump and measure the required length. Cut the return line and install one AN-08 90-degree hose end on the regulator end of the line and one AN-08 straight hose end on the fuel tank end of the line, as detailed in Section 4.
- Note:** Be sure to route all fuel lines clear of any moving suspension or drivetrain components and any exhaust components! Protect fuel lines from abrasion and road obstructions or debris.
- 2-3. Thread the 90-degree hose end side of the AN-06 return line onto the AN-06 return port fitting located on the Aeromotive regulator, and tighten. Use the 15602 (AN-06 union flare fitting) to connect the two straight AN-06 lines together at the rear of the car, near the tank.
  - 2-4. Remove the air intake ducting from the throttle body and position it out of the way.
  - 2-5. Note the location of, and remove any vacuum lines connected to the upper intake manifold and position them out of the way.
  - 2-6. Remove the throttle cable from the throttle body; referring to the appropriate vehicle service manual for the procedure for doing so.
  - 2-7. Unplug the TPS sensor, which is typically located on top of the throttle body.
  - 2-8. Remove the nameplate on the top of the upper intake manifold by removing 4 screws.
  - 2-9. Remove the upper intake manifold bolts (typically, there are 6 of them).
  - 2-10. Gently remove the upper intake from the engine. Place clean shop towels into or tape up the lower intake ports to prevent any material from entering the intake.
  - 2-11. Carefully clean the old gasket material from both manifolds, while preventing any debris from entering the intake manifold ports.
  - 2-12. Check for any dirt or debris around the fuel injectors. If any is evident, wash it off with some solvent parts cleaner or wipe it off with a clean shop towel.
  - 2-13. Disconnect the electrical connector at each injector, making note of the location of each.
  - 2-14. Disconnect both the supply and return fuel lines from the OEM fuel rails. These lines are attached by a special quick disconnect fitting which requires a special tool for removal. Place clean shop towels around the open fuel lines to catch any gasoline that may drip out and to prevent any dirt from entering the fuel lines.
  - 2-15. Remove the vacuum line from the fuel pressure regulator.
  - 2-16. Remove the bolts that attach the fuel rail to the lower intake (typically, there are 4 of them).
  - 2-17. Place clean shop towels around the injectors to catch any gasoline that may have spilled during their removal. Remove the injectors from the manifold by gently pulling upward on the fuel rail / injector assembly. Keep all injectors connected to the fuel rails. If an injector does pull out of the fuel rail, it may spill a large amount of fuel.
  - 2-18. Carefully remove the fuel injectors from the fuel rail.

- 2-19. Remove the old o-rings from the fuel injectors, inspect the injectors for any dirt or debris and clean if needed.
- 2-20. Coat the new fuel injector o-rings with a light oil or petroleum jelly to ease installation.
- 2-21. Carefully install the new fuel injector o-rings on the injectors.
- 2-22. Place a thin coat of light oil or petroleum jelly in the fuel rail fuel injector bores and in the lower intake manifold injector bores to help prevent cutting the o-rings during installation.
- 2-23. Carefully place the fuel injectors in the fuel rails. Rotate the injector to position the electrical connector on each fuel injector to the opposite side of the fuel rail as the mounting bracket.
- 2-24. Install the fuel rail that has AN-08 port in the bottom center on the driver side of the engine, with the port plug facing the front of the vehicle. This kit comes with 2 aluminum spacers, which get installed between the lower intake manifold and the fuel rail brackets on the driver's side to help with fuel rail to distributor clearance. After insuring that the injectors are properly seated in the intake manifold injector bores, install the driver side fuel rail mounting bolts, insuring that the fuel rail spacers are captured between the fuel rail bracket and the lower intake manifold. In some instances where an aftermarket intake manifold is used, you will need to shim the fuel rail out further to gain clearance between it and the distributor, this can be accomplished by using additional 1/4" flat washers, not included.
- 2-25. Install the passenger side fuel rail, being careful not to cut any of the o-rings during installation (This fuel rail does not require any spacers between the fuel rail bracket and the lower intake).



## Section 3 – Fuel Regulator Installation and Fuel Line Plumbing

- 3-1. In the vehicle's engine compartment, mount the supplied fuel pressure regulator in the location established in step 1-26. Using the supplied mounting bracket as a template, mark the bracket mounting holes and drill to accept a #10 screw.
- 3-2. Reattach the mounting bracket to the regulator and mount the regulator to the vehicle using two #10 screws, nuts and lock washers (not included).
- 3-3. Install one of the supplied AN-06 o-rings onto the ORB (cut-off) side of all three of the ORB-06 to AN-06 male flare fittings, if not already installed. Install one of these fittings into each of the ORB-06 inlet (side) ports located on either side of the supplied fuel pressure regulator. Install the remaining ORB-06 to AN-06 male flare fitting into the bottom, return port of the supplied fuel pressure regulator. See **FIGURE 3-1**

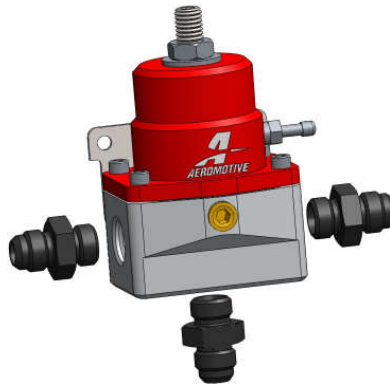
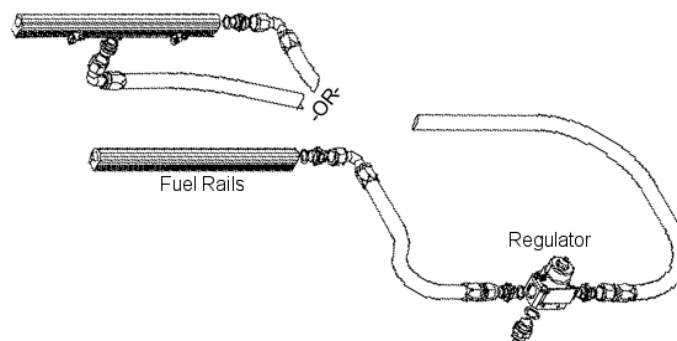

**FIGURE 3-1**

- 3-4. Install one of the supplied ORB-08 o-rings on the port (cutoff) side of each of four ORB-08 to AN-06 male flare fittings, if not already installed.
- 3-5. Install one of these ORB-08 to AN-06 male flare fittings on the back side (firewall end) of each fuel rail and one on the front side of the passenger side fuel rail. If there is adequate clearance between the distributor and the fuel rail on the driver's side rail, install the second fitting on the front side as well, if not, install the second fitting in the ORB-08 port located on the bottom center of the fuel rail.
- 3-6. Starting from the fuel rails, plan a route to run an AN-06 supply line from each fuel rail to each side of the regulator, see **FIGURE 3-2**. Cut the two supply lines to the determined length and install the AN-06 hose ends, as detailed in Section 4.

**Note: Be sure to route all fuel lines clear of any moving suspension or drivetrain components and any exhaust components! Protect fuel lines from abrasion and road obstructions or debris.**

- 3-7. Using the above steel braided hose assemblies, connect one end to the side of the fuel pressure regulator and the other end to the fuel rails, as shown in **FIGURE 3-2**, and tighten.



**Figure 3-2**

3-8. In the vehicle's engine compartment, find a suitable location near the fuel rails for the supplied Y-Block.

3-9. Starting from the fuel rails, plan a route to run an AN-06 supply line from each fuel rail on the firewall end to each side of the Y-block, see **FIGURE 3-3**. Cut the two supply lines to the determined length and install two straight AN-06 hose-ends on the Y-block end of each line, and two 90-deg. AN-06 hose-ends on the fuel rail end of each line, as detailed in Section 4.

**Note: Be sure to route all fuel lines clear of any moving suspension or drivetrain components and any exhaust components! Protect fuel lines from abrasion and road obstructions or debris.**

3-10. Using the above steel braided hose assemblies, connect one end to the Y-block and the other end to the fuel rails, as shown in **FIGURE 3-3**, and tighten.

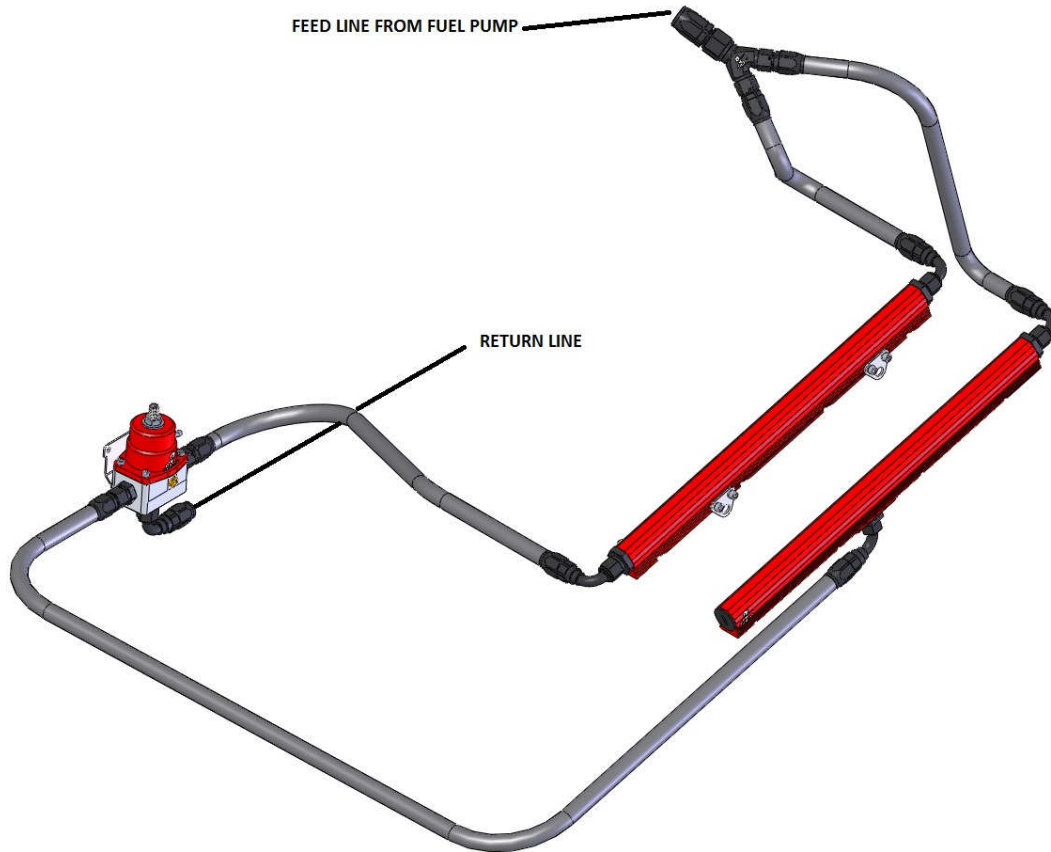

**FIGURE 3-3**

3-11. Starting from the outlet of the fuel pump / filter assembly, plan a route to run an AN-08 supply line from fuel pump / filter assembly to the Y-block. This line should be run along the same route you planned to run the return line in step 1.24. Cut the supply line to the determined length and install the AN-08 hose-ends, as detailed in Section 4.

**Note: Be sure to route all fuel lines clear of any moving suspension or drivetrain components and any exhaust components! Protect fuel lines from abrasion and road obstructions or debris.**

3-12. Using the above steel braided hose assembly, connect one end to the outlet of the fuel pump / filter assembly. Keeping both the supply line and return line from the Aeromotive fuel tank together, secure both lines to the vehicle along the predetermined route using the supplied tie-wraps and cushion clamps. Once both lines are to their destination, the supply line to the Y-block and the return line to the bottom of the regulator and tighten.

**Note: Be sure to route all fuel lines clear of any moving suspension or drivetrain components and any exhaust components! Protect fuel lines from abrasion and road obstructions or debris.**

3-13. Once the regulator is installed, attach the supplied fuel pressure gauge to the 1/8 NPT port on the fuel pressure regulator (keep port to re-install after pressure is set).

## Section 4 - Fuel Line Hose End Installation:

### CAUTION:

**When assembling this product, wear eye goggles and other safety apparel as needed to protect yourself from debris and sharp edges.**

4-1. Wrap hose with masking tape at desired cutoff length. Cut hose through masking tape squarely to desired length using a cut-off machine or a fine tooth hacksaw. Remove the masking tape.

4-2. Unthread the hose socket from the rest of the hose end fitting.



4-3. Insert hose in the socket with a twisting and pushing motion until the hose is fully seated in the socket.



4-4. Using a grease pencil, marker or tape, mark the location of the hose in relation to the hose socket that you just installed.

4-5. Using a light oil, lubricate the inside of the hose and hose end mating parts.

4-6. Carefully thread the hose end onto the hose socket, making sure that the hose does not push out of socket, by observing the mark you placed on the hose in step 3-4.



4-7. Using a properly sized wrench, complete threading the two components together (The maximum allowable gap between the two fitting components is .030 inches).



4-8. Inspect the hose for push out by comparing the mark you made on the hose in step D to the hose end socket location.

4-9. Clean all debris from exterior and interior of hose.

4-10. All lines should be tested to twice their operation pressure prior to use.

## Section 5 – Final Checks and System Start-up

5-1. **Ensure that any spilled gasoline and any gasoline soaked shop towels are cleaned up and removed from the vicinity of the vehicle!**

5-2. Carefully lower the car onto the ground.

5-3. Fill the fuel tank with gasoline and check for any leaks in the system, if any leaks are found repair immediately.

**CAUTION: While performing the following steps, if any fuel leaks are detected, immediately turn the ignition of OFF, remove any spilled fuel and repair the leak(s) before proceeding!**

5-4. Reconnect the battery and turn the ignition to the ON position **WITHOUT** starting the car. After several seconds, check the fuel pressure. If there is no fuel pressure, turn the ignition key to the OFF position, wait one minute, return the ignition to the ON position, and recheck the fuel pressure. Repeat this ignition OFF and ON procedure until the fuel pressure gauge registers fuel pressure.

**5-5. With the fuel pressure gauge registering fuel system pressure, check for fuel leaks throughout the entire fuel system! If any fuel leaks are found, turn the ignition key to the OFF position, remove any spilled fuel and repair the leak before proceeding!**

5-6. Once the fuel pressure gauge registers fuel system pressure and there are no fuel leaks, start the engine and adjust the regulator to the desired fuel pressure. Turning the adjustment screw clockwise will increase fuel pressure. OEM regulators are typically set at approximately 43 psi, without the vacuum line attached. The fuel pressure adjustment range for this regulator is 35-80 psi.

5-7. Once the desired fuel pressure is achieved, tighten the regulator adjustment jam nut and attach the vacuum line. Remove gauge and re-install 1/8" NPT port plug.

5-8. Test drive the car to insure proper operation and re-check the fuel system for leaks. **If any leaks are found, immediately discontinue use of the vehicle and repair the leak(s)!**



**WARNING:** This product can expose you to chemicals, including chromium, which is known to the State of California to cause cancer or birth defects or other reproductive harm. For more information, visit: [www.p65Warnings.ca.gov](http://www.p65Warnings.ca.gov)

### ***AEROMOTIVE, INC. LIMITED WARRANTY***

This Aeromotive Product, with proof of purchase dated on or after January 1, 2003, is warranted to be free from defects in materials and workmanship for a period of one year from the original date of purchase. No warranty claim will be valid without authentic, dated proof of purchase.

This warranty is to the original retail purchaser and none other and is available directly from Aeromotive and not through any point of distribution or purchase.

If a defect is suspected, the retail purchaser must contact Aeromotive directly to discuss the problem, possible solutions and obtain a Return Goods Authorization (RGA), if deemed necessary by the company. Please call 913-647-7300 and dial option 3 for the technical service dept. All returns must be shipped freight pre-paid to the company and with valid RGA before they will be processed.

Aeromotive will examine any product returned with the proper authorization to determine if the failure resulted from a defect or from abuse, improper installation, misapplication or alteration. Aeromotive will then, at it's sole discretion, return, repair or replace the product.

If any Aeromotive product is determined defective, buyer's exclusive remedy is limited in value to the sale price of the good. In no event shall Aeromotive be liable for incidental or consequential damages.

Aeromotive expressly retains the right to make changes and improvements in any product it manufactures and sells at any time. These changes and improvements may be made without notice at any time and without any obligation to change the catalogs or printed materials.

Aeromotive expressly retains the right to discontinue at any time and without notice any Aeromotive product that it manufactures or sells.

This warranty is limited and expressly limits any implied warranty to one year from the date of the original retail purchase on all Aeromotive products.

No person, party or corporate entity other than Aeromotive shall have the right to: determine whether or not this Limited Warranty is applicable to any Aeromotive product, authorize any action whatsoever under the terms and conditions of this Limited Warranty, assume any obligation or liability of any nature whatsoever on behalf of Aeromotive under the terms and conditions of this Limited Warranty.

This Limited Warranty covers only the product itself and not the cost of installation or removal.

This Limited Warranty is in lieu of and expressly excludes any and all other warranties, expressed or implied. This Limited Warranty gives you specific legal rights, and you may also have other rights which vary from state to state.