



AEROMOTIVE
Part # 14101
86-98 Ford 5.0 Liter
INSTALLATION INSTRUCTIONS



CAUTION:

Installation of this product requires detailed knowledge of automotive systems and repair procedures. We recommend that this installation be carried out by a qualified automotive technician.

Installation of this product requires handling of gasoline. Ensure you are working in a well ventilated area with an approved fire extinguisher nearby. Extinguish all open flames, prohibit smoking and eliminate all sources of ignition in the area of the vehicle before proceeding with the installation.

When installing this product, wear eye goggles and other safety apparel as needed to protect yourself from debris and sprayed gasoline.

WARNING!

The fuel system is under pressure. Do not open the fuel system until the pressure has been relieved. Refer to the appropriate vehicle service manual for the procedure and precautions for relieving the fuel system pressure.

The enclosed Aeromotive fuel rails utilize o-ring sealed AN-08 style ports; these ports are NOT PIPE THREAD and utilize NO THREAD SEALANT. To use the enclosed fuel rails in your vehicle's fuel system you must install the necessary adapter fittings and o-rings, high pressure fuel lines and regulator to adapt your system to the configuration and ports of these fuel rails. Please call for a catalog of the complete line of quality Aeromotive products.

The enclosed Aeromotive fuel rails are intended to be installed on an unmodified OEM intake manifold of the identified application. Aeromotive cannot guarantee the proper fitment on aftermarket intake manifolds and the end user is responsible for verifying proper fitment and assumes all liability.

Due to the large number of applications which these fuel rails fit, please refer to your vehicles service manual for installation instructions. At the end of the instructions you will find a diagram of how these fuel rails assemble in your fuel system.

Note: 94-95 Mustang GT 5.0L engines, or any engine using a Thunderbird low profile distributor, may require a small cap conversion or the MSD P/N 8455 Billet Distributor for clearance.

Aeromotive system components are not legal for sale or use on emission controlled motor vehicles.

This kit contains the following parts:

2ea 14101 Fuel Rails

2ea Spacers (for driver side rail)

The following steps are typical of most installations:

1. Once the engine has been allowed to cool, disconnect the negative battery cable and relieve fuel system pressure, referring to the appropriate vehicle service manual for the procedure on doing so.
 2. Remove the air intake ducting from the throttle body and position it out of the way.
 3. Note the location of and remove any vacuum lines connected to the upper intake manifold and position them out of the way.
 4. Remove the throttle cable from the throttle body; referring to the appropriate vehicle service manual for the procedure for doing so.
 5. Unplug the TPS sensor, which is typically located on top of the throttle body.
 6. Remove the nameplate on the top of the upper intake manifold by removing 4 screws.
 7. Remove the upper intake manifold bolts (Typically there are 6 of them).
 8. Gently remove the upper intake from the engine. Place clean shop towels into or tape up the lower intake ports to prevent any material from entering the intake.
 9. Carefully clean the old gasket material from both manifolds, while preventing any debris from entering the intake manifold ports.
 10. Check for any dirt or debris around the fuel injectors. If any is evident, wash it off with some solvent parts cleaner or wipe it off with a clean shop towel.
 11. Disconnect the electrical connector at each injector, making note of the location of each.
 12. Disconnect both the supply and return fuel lines from the OEM fuel rails. These lines are attached by a special quick disconnect fitting which requires a special tool for removal. Place clean shop towels around the open fuel lines to catch any gasoline that may drip out and to prevent any dirt from entering the fuel lines.
 13. Remove the vacuum line from the fuel pressure regulator.
 14. Remove the bolts that attach the fuel rail to the lower intake (Typically there are 4 of them).
 15. Place clean shop towels around the injectors to catch any gasoline that may be spilled during their removal. Remove the injectors from the manifold by gently pulling upward on the fuel rail / injector assembly. Keep all injectors connected to the fuel rails. If an injector does pull out of the fuel rail, it may spill a large amount of fuel.
- Failure to satisfy all safety considerations will result in fire, explosion, injury and/or loss of life to yourself and/or others.**
16. Carefully remove the fuel injectors from the OEM fuel rails.
 17. Remove the old o-rings from the fuel injectors, inspect the injectors for any dirt or debris and clean if needed. It is suggested that the old o-rings be replaced, contact your local parts store or dealer to purchase the correct replacement o-rings.

18. Carefully install the new fuel injector o-rings on the injectors.

When installing o-rings it is important to place a small amount of light oil on both the o-ring and the mating surface to ease installation and prevent damaging the o-ring.

19. Place a thin coat of light oil in the fuel rail fuel injector bores and in the lower intake manifold injector bores to help prevent cutting the o-rings during installation.

20. Carefully place the fuel injectors in the fuel rails. Position the electrical connector on each fuel injector to the opposite side of the fuel rail as the mounting bracket.

21. Install the fuel rail that has an AN-08 port plug in one end on the driver side, with the port plug facing the front of the vehicle. This kit comes with 2 aluminum spacers which get installed between the lower intake manifold and the fuel rail brackets. In some instances it will be required to install additional flat washers to space the rail out further from the distributor. After insuring that the injectors are properly seated in the intake manifold injector bores, install the driver side fuel rail mounting bolts, insuring that the fuel rail spacers are captured between the fuel rail bracket and the lower intake manifold.

22. Install the passenger side fuel rail, being careful not to cut any of the o-rings during installation (This fuel rail does not require any spacers between the fuel rail bracket and the lower intake).

23. With the Aeromotive fuel rail properly secured to the intake manifold, Move the fuel injector vertically downward until it bottoms out on the intake manifold, In this downward position, inspect the upper fuel injector o-ring (on the fuel rail side) and insure it is fully covered by the fuel rail injector bore. If any of the o-ring is exposed, loosen the fuel rail bracket screws and adjust the installation height until the o-ring is no longer exposed and retighten the bracket screws. In the situation where the fuel injector has no vertical travel, either the fuel rail brackets can be adjusted or the brackets shimmed until the fuel injector fits freely. Do not pressurize the fuel rail until the proper fuel rail installation height is achieved.

24. Install the appropriate union fittings and o-rings on each fuel rail, we recommend Aeromotive p/n 15605 for AN-06 or Aeromotive 15607 for AN-08.

25. Using an after-market fuel pressure regulator (We recommend Aeromotive 13101, 13109, or 13129) and high pressure fuel lines and fittings, plumb the remainder of the fuel system. Below is an example of a typical installation.

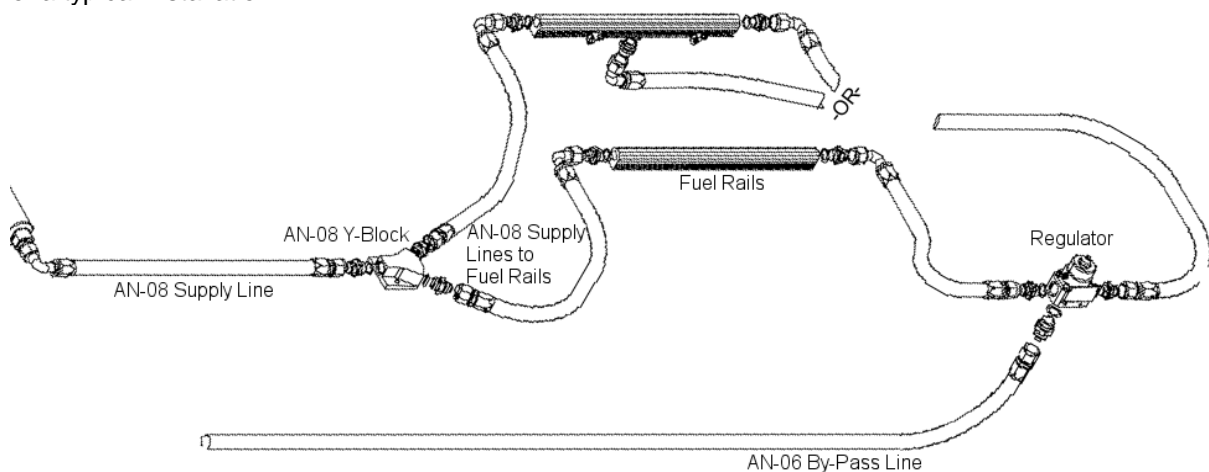

26. If you intend to retain the factory feed and return lines, Aeromotive offers the 14102 fuel rail system, including the 15101 and 15102 fuel line adapters.

Ensure that any spilled gasoline and any gasoline soaked shop towels are cleaned up and removed from the vicinity of the vehicle!

27. Reconnect the battery and turn the ignition to the ON position **WITHOUT** starting the car. After several seconds, check the fuel pressure. If there is no fuel pressure, turn the ignition key to the OFF position, wait one minute, return the ignition to the ON position, and recheck the fuel pressure. Repeat this ignition OFF and ON procedure until the fuel pressure gauge registers fuel pressure.

28. With the fuel pressure gauge registering fuel system pressure, check for fuel leaks from and around all the fuel system components and all fuel lines and connections! If any fuel leaks are found, turn the ignition key to the OFF position, remove any spilled fuel and repair the leak before proceeding!

29. Once the fuel pressure gauge registers fuel system pressure and there are no fuel leaks, start the engine and adjust the regulator to the desired fuel pressure.

30. Once the desired fuel pressure is achieved, tighten the regulator adjustment jam nut and attach the vacuum line.

31. Turn off the engine and allow it to cool.

32. Test drive the car to insure proper operation and re-check the fuel system for leaks. **If any leaks are found, immediately shutoff the engine and repair the leak(s)!**

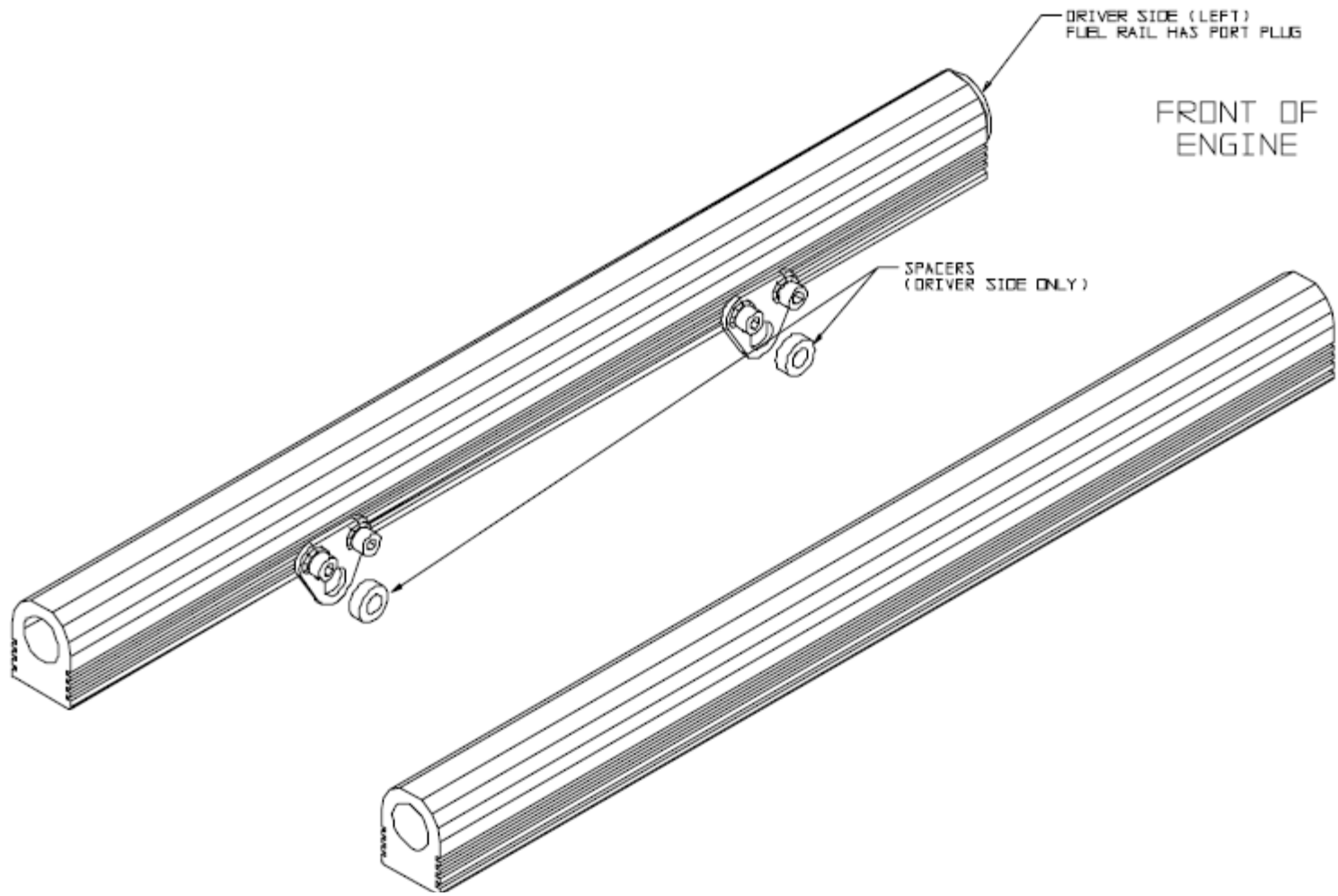

AEROMOTIVE, INC.
7805 Barton Street, Lenexa, KS 66214
913-647-7300 fax 913-647-7207
www.aeromotiveinc.com



WARNING: This product can expose you to chemicals, including chromium, which is known to the State of California to cause cancer or birth defects or other reproductive harm. For more information, visit: www.p65Warnings.ca.gov

AEROMOTIVE, INC. LIMITED WARRANTY

This Aeromotive Product, with proof of purchase dated on or after January 1, 2003, is warranted to be free from defects in materials and workmanship for a period of one year from the original date of purchase. No warranty claim will be valid without authentic, dated proof of purchase.

This warranty is to the original retail purchaser and none other and is available directly from Aeromotive and not through any point of distribution or purchase.

If a defect is suspected, the retail purchaser must contact Aeromotive directly to discuss the problem, possible solutions and obtain a Return Goods Authorization (RGA), if deemed necessary by the company. Please call 913-647-7300 and dial option 3 for the technical service dept. All returns must be shipped freight pre-paid to the company and with valid RGA before they will be processed.

Aeromotive will examine any product returned with the proper authorization to determine if the failure resulted from a defect or from abuse, improper installation, misapplication or alteration. Aeromotive will then, at it's sole discretion, return, repair or replace the product.

If any Aeromotive product is determined defective, buyer's exclusive remedy is limited in value to the sale price of the good. In no event shall Aeromotive be liable for incidental or consequential damages.

Aeromotive expressly retains the right to make changes and improvements in any product it manufactures and sells at any time. These changes and improvements may be made without notice at any time and without any obligation to change the catalogs or printed materials.

Aeromotive expressly retains the right to discontinue at any time and without notice any Aeromotive product that it manufactures or sells.

This warranty is limited and expressly limits any implied warranty to one year from the date of the original retail purchase on all Aeromotive products.

No person, party or corporate entity other than Aeromotive shall have the right to: determine whether or not this Limited Warranty is applicable to any Aeromotive product, authorize any action whatsoever under the terms and conditions of this Limited Warranty, assume any obligation or liability of any nature whatsoever on behalf of Aeromotive under the terms and conditions of this Limited Warranty.

This Limited Warranty covers only the product itself and not the cost of installation or removal.

This Limited Warranty is in lieu of and expressly excludes any and all other warranties, expressed or implied. This Limited Warranty gives you specific legal rights, and you may also have other rights which vary from state to state.