



**AEROMOTIVE**  
**Part # 17245**  
**H.O. Fuel System**  
**INSTALLATION INSTRUCTIONS**

**CAUTION:**

Installation of this product requires detailed knowledge of automotive systems and repair procedures. We recommend that this installation be carried out by a qualified automotive technician.

Installation of this product requires handling of gasoline. Ensure you are working in a well ventilated area with an approved fire extinguisher nearby. Extinguish all open flames, prohibit smoking and eliminate all sources of ignition in the area of the vehicle before proceeding with the installation.

When installing this product, wear eye goggles and other safety apparel as needed to protect yourself from debris and sprayed gasoline.

**WARNING!**

The fuel system is under pressure. Do not open the fuel system until the pressure has been relieved. Refer to the appropriate vehicle service manual for the procedure and precautions for relieving the fuel system pressure.

Aeromotive system components are not legal for sale or use on emission controlled motor vehicles.

**This kit contains the following parts:**

1 ea p/n 11219 Pump	16 ft AN-06 stainless steel braided line
1 ea p/n 12324 Filter	4 ft AN-08 stainless steel braided line
1 ea p/n 16301 fuel pump wiring kit	2 ea AN-06 straight hose end
1 ea p/n 15605 AN-06 / AN-08 Reducer union	1 ea AN-08 straight hose end
2 ea p/n 15610 AN-08 / AN-010 Reducer union	1 ea AN-08 90-degree hose end
2 ea AN-08 o-rings	12 ea tie-wraps
2 ea AN-10 o-rings	6 ea Cushioned line clamps
	6 ea self tapping screws

If you are using a stock fuel tank, install a reservoir style sump in the bottom-rear of your fuel tank. Exercise extreme caution and follow all manufacturer's recommendations when installing a reservoir style sump.

If you choose not to install a reservoir style sump, then you must install a high flow capacity fuel tank pickup. (Installing a high flow pickup instead of a reservoir style sump may shorten the fuel pump life and cause driveability problems. Stock fuel tanks have a small inlet reservoir that is quickly emptied by a high flow fuel system, causing pump starvation and cavitation. When using a pickup, you should maintain at least ½ tank of fuel in the vehicle at all times, to avoid emptying the stock inlet reservoir.)

**The following steps are typical of most installations:**

Section 1 - Fuel pump installation

Section 2 – Fuel line hose end installation

Section 3 – Electrical Installation

Section 4 – Final checks and system start-up

## Section 1 - Fuel pump installation:

**DO NOT RUN THE PUMP DRY!** Excessive wear will result if the pump runs dry.

**DO NOT DISASSEMBLE THE PUMP!** Disassembly will throw the pump out of calibration and void all warranties on this product.

**DO NOT ATTEMPT TO ADJUST THE OUTLET PRESSURE SCREW!** The maximum outlet pressure has been preset at the factory and locked in its current position. Adjusting it will void all warranties on this product.

- 1-1. Once the engine has been allowed to cool, disconnect the negative battery cable and relieve the fuel system pressure.
- 1-2. Raise the vehicle and support it with jack stands.
- 1-3. Referring to the appropriate vehicle service manual for instructions, drain and disconnect any electrical and fuel component connections, plug the open fuel line ends and remove the existing pump.
- 1-4. Find a suitable place on the vehicle chassis to mount the Aeromotive fuel pump. Make sure the location will accommodate the pump mounting bolts, will position the pump lower than the fuel tank, is clear of the exhaust, is clear of any moving suspension or drivetrain components and will keep the pump clear of road obstructions or debris.
- 1-5. Place each of the two AN-10 o-rings on the AN-10 side of the two AN-08 / AN-10 Union Fittings. Thread the AN-10 side of each of the union fittings into each of the AN-10 ports on the fuel filter. Place one of the AN-08 o-rings on the AN-08 side of the union on the outlet side of the fuel filter and thread the filter into the inlet side of the Aeromotive fuel pump.

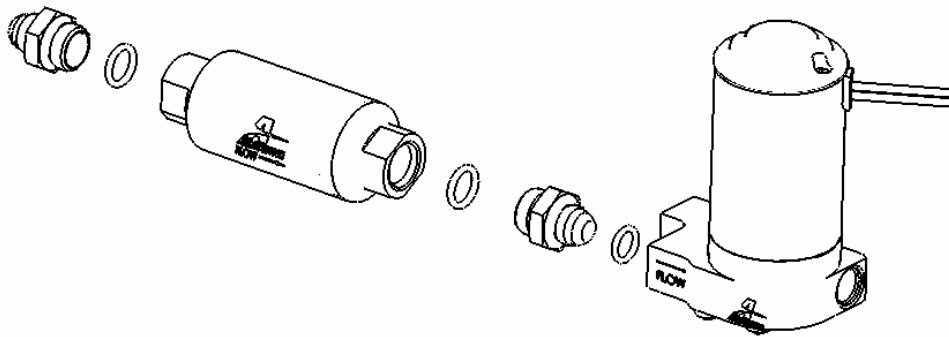

- 1-6. Making sure to mount the pump in the upright position and using the pump mounting bracket as a template, mark and drill two mounting holes to accept  $\frac{1}{4}$ " bolts (not provided). Mount the pump bracket using two  $\frac{1}{4}$ " bolts, nuts and lock washers (Not provided). Slide the pump into the bracket and tighten the clamping bolt. **Do not over-tighten the clamping bolt. Doing so can permanently damage the pump motor!**

**Note: Be sure to route all fuel lines clear of any moving suspension or drivetrain components, and any exhaust components! Protect fuel lines from abrasion and road obstructions or debris.**

1-7. Using the supplied 90-degree AN-08 hose end and the supplied straight AN-08 hose end as a guide, measure the length of AN-08 steel braided line needed to connect the fuel tank or fuel cell outlet to the fuel pump / filter assembly inlet. This section of fuel line should be as short as possible to reduce the tendencies for vapor lock, cavitation, and premature wear of your Aeromotive fuel pump.

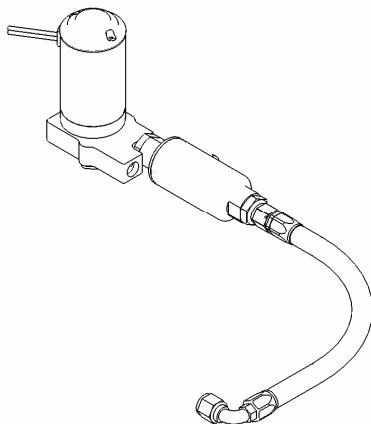

1-8. Cut and assemble the steel braided hose and hose ends as shown in Section 3.

1-9. Using the above steel braided hose assembly, connect the 90-degree end to the outlet of the fuel tank / fuel cell and the straight end to the fuel pump / filter assembly inlet and tighten.

1-10. In the vehicles engine compartment determine where your carburetors fuel feed line will be feed from.

1-11. Place one of the AN-08 o-rings on the AN-08 / AN-06 union fitting and thread the AN-08 side of the fitting into the fuel pump outlet.

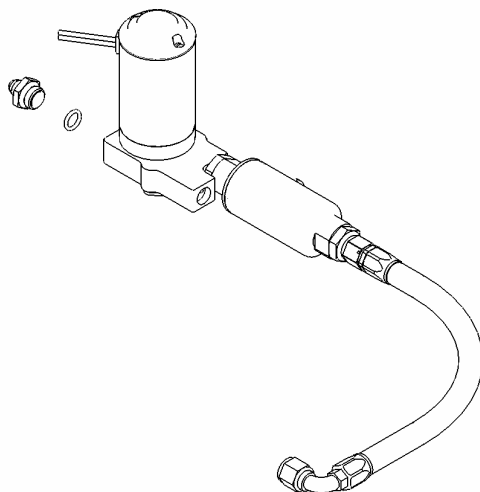

1-12. Using the two supplied straight AN-06 hose ends as a guide, measure the length of AN-06 steel braided line needed to connect the fuel pump assembly outlet to the fuel pressure regulator.

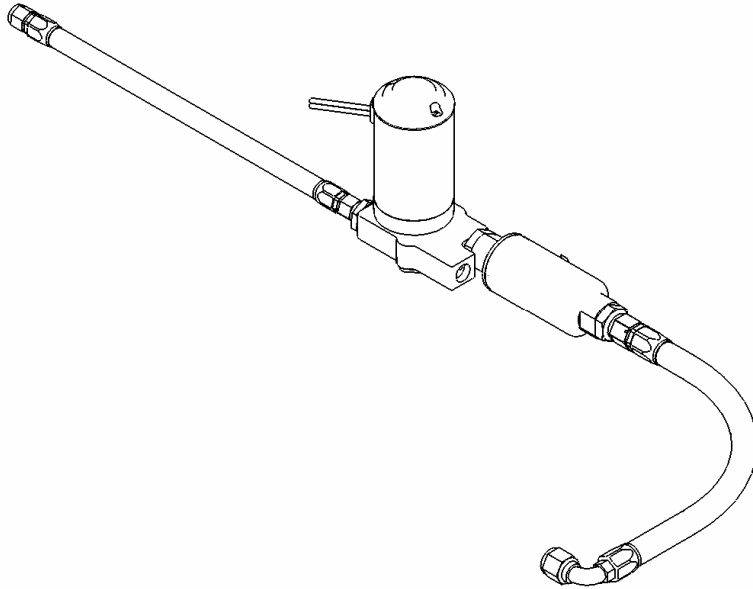

1-13. Cut and assemble the steel braided hose and hose ends as shown in Section 3.

1-14. Using the above steel braided hose assembly, connect one end to the outlet of the fuel pump / filter assembly outlet and the other to your carburetors fuel feed inlet.

## Section 2 - Fuel Line Hose End Installation:

### CAUTION:

**When assembling this product, wear eye goggles and other safety apparel as needed to protect yourself from debris and sharp edges.**

2-1. Wrap hose with masking tape at desired cutoff length. Cut hose through masking tape squarely to desired length using a cut-off machine or a fine tooth hacksaw. Remove the masking tape.

2-2. Unthread the hose socket from the rest of the hose end fitting.



2-3. Insert hose in the socket with a twisting and pushing motion until the hose is fully seated in the socket.



2-4. Using a grease pencil, marker or tape, mark the location of the hose in relation to the hose socket that you just installed.

2-5. Using a light oil, lubricate the inside of the hose and hose end mating parts.

2-6. Carefully thread the hose end onto the hose socket, making sure that the hose does not push out of socket, by observing the mark you placed on the hose in step 3-4.

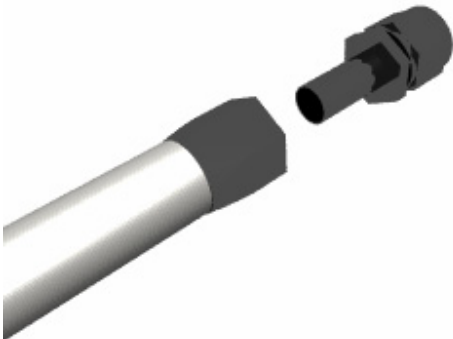

2-7. Using a properly sized wrench, complete threading the two components together (The maximum allowable gap between the two fitting components is .030 inches).



2-8. Inspect the hose for push out by comparing the mark you made on the hose in step D to the hose end socket location.

2-9. Clean all debris from exterior and interior of hose.

2-10. All lines should be tested to twice their operation pressure prior to use.

## Section 3 - Electrical Installation:

- 3-1. Find a suitable place to mount the supplied relay, the relay is typically mounted by the OEM fuel pump wiring connector (***Never mount the relay inside of the fuel tank or next to fuel tank vents!***). Ensure the relay and any associated parts are clear of the exhaust, any moving suspension or drivetrain components and any possible road obstructions or debris.
- 3-2. Attach the OEM fuel pump wires (These typically are the red and black wires from the OEM wiring harness going to the fuel tank) to relay terminals 85 and 86 using two of the supplied blue female blade connectors (See Figure 3-1 Below).

**Note: Be sure to route all electrical wires clear of any moving suspension or drivetrain components, and any exhaust components! Protect wires from abrasion and road obstructions or debris.**

- 3-3. Find a suitable location for mounting the supplied circuit breaker. For optimal circuit protection, the circuit breaker needs to be mounted as close to the battery as possible.
- 3-4. Connect terminal number 30 on the relay to the circuit breaker by using the supplied red 10 ga. wire, one of the yellow female blade connectors on the relay end of the wire and one of the yellow #10 ring connectors on the circuit breaker side of the wire.

**Note: Be sure to route all electrical wires clear of any moving suspension or drivetrain components and any exhaust components! Protect wires from abrasion and road obstructions or debris.**

- 3-5. Connect terminal number 87 on the relay to the positive terminal on the fuel pump. This is accomplished by using the supplied red 10 ga wire, one of the yellow female blade connectors on the relay side of the wire and one of the yellow butt connectors (or appropriate connector for the installation) on the fuel pump side of the wire.
- 3-6. Connect the negative terminal on the fuel pump to a clean chassis ground using the supplied black 10 ga. wire and one yellow #10 ring connector and one yellow butt connector.
- 3-7. Connect 12VDC to the circuit breaker using the supplied red wire and one of the yellow #10 ring connectors and the supplied yellow 3/8" ring connector.
- 3-8. Ensure that electrical components and wires are connected properly (See Figure 3-1) and are clear of any moving suspension or drivetrain components and any exhaust components! Protect wires from abrasion and road obstructions or debris.

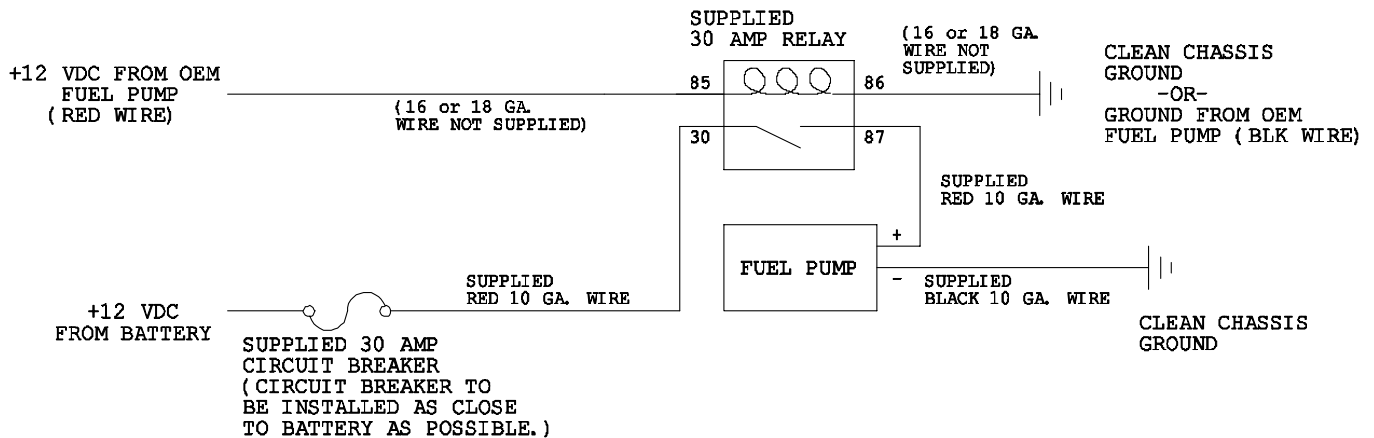

Figure 3-1

## Section 4 – Final Checks and System Start-up

4-1. **Ensure that any spilled gasoline and any gasoline soaked shop towels are cleaned up and removed from the vicinity of the vehicle!**

4-2. Carefully lower the car onto the ground.

4-3. Fill the fuel tank with gasoline and check for any leaks in the system, if any leaks are found repair immediately.

**CAUTION: While performing the following steps, if any fuel leaks are detected, immediately turn the ignition of OFF, remove any spilled fuel and repair the leak(s) before proceeding!**

4-4. Reconnect the battery and turn the ignition to the ON position **WITHOUT** starting the car. After several seconds, check the fuel pressure. If there is no fuel pressure, turn the ignition key to the OFF position, wait one minute, return the ignition to the ON position, and recheck the fuel pressure. Repeat this ignition OFF and ON procedure until the fuel pressure gauge registers fuel pressure.

**4-5. With the fuel pressure gauge registering fuel system pressure, check for fuel leaks throughout the entire fuel system! If any fuel leaks are found, turn the ignition key to the OFF position, remove any spilled fuel and repair the leak before proceeding!**

4-6. Once the fuel pressure gauge registers fuel system pressure and there are no fuel leaks, start the engine.

**4-7. Test drive the car to ensure proper operation and re-check the fuel system for leaks. If any leaks are found, immediately discontinue use of the vehicle and repair the leak(s)!**

Thanks for purchasing another quality product designed, engineered and manufactured in Kansas City,  
USA!

---

**AEROMOTIVE, INC.**  
7805 Barton Street, Lenexa, KS 66214  
913-647-7300 fax 913-647-7207  
[www.aeromotiveinc.com](http://www.aeromotiveinc.com)

## ***AEROMOTIVE, INC. LIMITED WARRANTY***

This Aeromotive Product, with proof of purchase dated on or after January 1, 2003, is warranted to be free from defects in materials and workmanship for a period of one year from the original date of purchase. No warranty claim will be valid without authentic, dated proof of purchase.

This warranty is to the original retail purchaser and none other and is available directly from Aeromotive and not through any point of distribution or purchase.

If a defect is suspected, the retail purchaser must contact Aeromotive directly to discuss the problem, possible solutions and obtain a Return Goods Authorization (RGA), if deemed necessary by the company. Please call 913-647-7300 and dial option 3 for the technical service dept. All returns must be shipped freight pre-paid to the company and with valid RGA before they will be processed.

Aeromotive will examine any product returned with the proper authorization to determine if the failure resulted from a defect or from abuse, improper installation, misapplication or alteration. Aeromotive will then, at it's sole discretion, return, repair or replace the product.

If any Aeromotive product is determined defective, buyer's exclusive remedy is limited in value to the sale price of the good. In no event shall Aeromotive be liable for incidental or consequential damages.

Aeromotive expressly retains the right to make changes and improvements in any product it manufactures and sells at any time. These changes and improvements may be made without notice at any time and without any obligation to change the catalogs or printed materials.

Aeromotive expressly retains the right to discontinue at any time and without notice any Aeromotive product that it manufactures or sells.

This warranty is limited and expressly limits any implied warranty to one year from the date of the original retail purchase on all Aeromotive products.

No person, party or corporate entity other than Aeromotive shall have the right to: determine whether or not this Limited Warranty is applicable to any Aeromotive product, authorize any action whatsoever under the terms and conditions of this Limited Warranty, assume any obligation or liability of any nature whatsoever on behalf of Aeromotive under the terms and conditions of this Limited Warranty.

This Limited Warranty covers only the product itself and not the cost of installation or removal.

This Limited Warranty is in lieu of and expressly excludes any and all other warranties, expressed or implied. This Limited Warranty gives you specific legal rights, and you may also have other rights which vary from state to state.