



AEROMOTIVE Part # 11115
INSTALLATION INSTRUCTIONS
Not For Street Use!

CAUTION:

Installation of this product requires detailed knowledge of automotive systems and repair procedures. We recommend that this installation be carried out by a qualified automotive technician.

Installation of this product requires handling of gasoline. Ensure you are working in a well ventilated area with an approved fire extinguisher nearby. Extinguish all open flames, prohibit smoking and eliminate all sources of ignition in the area of the vehicle before proceeding with the installation.

When installing this product, wear eye goggles and other safety apparel as needed to protect yourself from debris and sprayed gasoline.

WARNING!

The fuel system is under pressure. Do not open the fuel system until the pressure has been relieved. Refer to the appropriate vehicle service manual for the procedure and precautions for relieving the fuel system pressure.

The enclosed Aeromotive fuel pump utilizes an o-ring sealed AN-12 style outlet ports; this port is **NOT PIPE THREAD** and utilizes **NO THREAD SEALANT**.

To use this pump in your vehicle's fuel system, we strongly recommend the following:

Gravity feed the pump by mounting it lower than the fuel cell.

Utilize high pressure fuel lines, fittings and o-rings for all connections from the fuel cell to the engine.

Failure to follow the above recommendations may result in fuel leakage, bursting of the fuel lines, poor vehicle performance and/or decreased fuel pump life! Improper installation will void all warranties for this product!

Aeromotive system components are not legal for sale or use on emission controlled motor vehicles.

Performance Specifications: Model 11115

Fuel Compatibility	Gasoline & Methyl Alcohol
Port Sizes	1 ¼" Inlet & AN-12 Outlet

Pump mounting:

Pump should be mounted as low as possible to ease priming.

Due to the large number of applications, no specific mounting instructions are provided.

Pump should turn at half the engine speed.

Recommend a 28-tooth pulley on the pump and a 14-tooth pulley on the crankshaft.

Call for details on Aeromotive mounting kits.

The following steps are typical of most installations:

1. Once the engine has been allowed to cool, relieve the fuel system pressure and disconnect the negative battery cable.
2. Raise the vehicle and support it with jack stands.
3. Find a suitable place on the engine or chassis to mount the Aeromotive fuel pump. Make sure the location will accommodate the pump mounting bracket, will position the pump as low as possible, is clear of the exhaust, is clear of any moving suspension or drivetrain components and will keep the pump clear of track obstructions or debris.

Note: Be sure to route all fuel lines clear of any moving suspension or drivetrain components, and any exhaust components! Protect fuel lines from abrasion and track obstructions or debris.

4. Acquire a 14-tooth, timing belt pulley for the crankshaft, a 28-tooth timing belt pulley for the pump and a ½" wide timing belt of the desired length. Call Aeromotive for details on mounting kits.
5. Determine which direction the fuel pump shaft will rotate. The direction the shaft is rotated will determine which port is the inlet and which is the outlet. Using Figure 1a & 1b as a reference identify the fuel pump inlet and outlet ports. If the fuel pump shaft is rotated in a clockwise direction as viewed from the front of the pump the inlet and outlet ports will be as shown in Figure 1a. If the fuel pump shaft is rotated in a counter-clockwise direction as viewed from the front of the pump the inlet as shown in figure 1a now becomes the outlet and the outlet in figure 1a is now the inlet, this is shown in figure 1b.

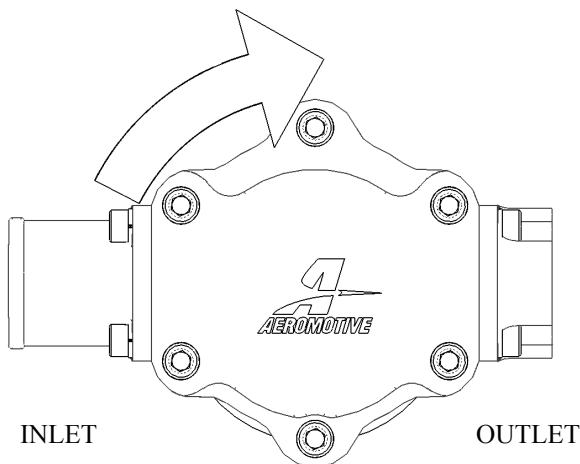

Figure 1a

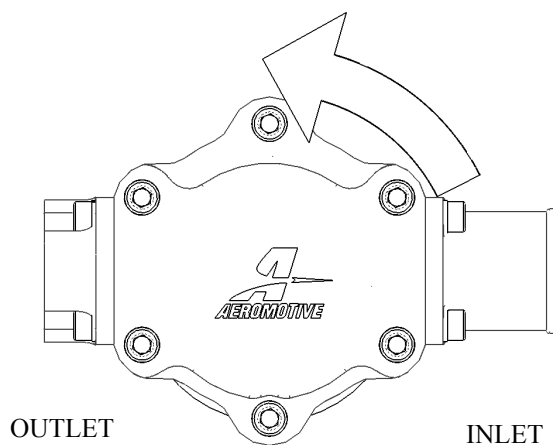

Figure 1b

6. Connect the fuel cell sump to the fuel filter inlet, utilizing a minimum of 1 ¼" fuel line. Next, connect the fuel filter outlet to the fuel pump inlet utilizing a minimum of AN-10 steel braided fuel line, refer to Figure 1 for determining the fuel pump inlet.
7. Connect the fuel pump outlet to the vehicle's fuel system. **Make sure you use high pressure (1000 psi minimum) fuel line for this connection!**

Note: Be sure to route all fuel lines clear of any moving suspension or drivetrain components, and any exhaust components! Protect fuel lines from abrasion and track obstructions or debris.

8. If you are using this fuel pump with an EFI style fuel system we recommend using Aeromotive p/n 13110 Fuel Pressure Regulator.
9. **Ensure that any spilled fuel and any fuel soaked shop towels are cleaned up and removed from the vicinity of the vehicle!**

CAUTION: While performing the following steps, if any fuel leaks are detected, immediately turn the ignition to OFF, remove any spilled fuel and repair the leak(s) before proceeding!

10. Turn the engine over **without starting the engine**, allow the pump to prime for several seconds and check the fuel pressure. If there is no pressure, wait one minute, then turn the engine over, recheck the pressure. Repeat this procedure until the gauge registers pressure or you detect a fuel leak.
11. Carefully lower the vehicle to the ground.
12. Test-drive the vehicle to insure proper operation and re-check the fuel system for leaks. **If any leaks are found, immediately discontinue use of the vehicle and repair the leak(s)!**

Thanks for purchasing another quality product designed, engineered and manufactured in Kansas City,
USA!

AEROMOTIVE, INC.
7805 Barton Street, Lenexa, KS 66214
913-647-7300 fax 913-647-7207

AEROMOTIVE, INC. LIMITED WARRANTY

This Aeromotive Product, with proof of purchase dated on or after January 1, 2003, is warranted to be free from defects in materials and workmanship for a period of one year from the original date of purchase. No warranty claim will be valid without authentic, dated proof of purchase.

This warranty is to the original retail purchaser and none other and is available directly from Aeromotive and not through any point of distribution or purchase.

If a defect is suspected, the retail purchaser must contact Aeromotive directly to discuss the problem, possible solutions and obtain a Return Goods Authorization (RGA), if deemed necessary by the company. Please call 913-647-7300 and dial option 3 for the technical service dept. All returns must be shipped freight pre-paid to the company and with valid RGA before they will be processed.

Aeromotive will examine any product returned with the proper authorization to determine if the failure resulted from a defect or from abuse, improper installation, misapplication or alteration. Aeromotive will then, at it's sole discretion, return, repair or replace the product.

If any Aeromotive product is determined defective, buyer's exclusive remedy is limited in value to the sale price of the good. In no event shall Aeromotive be liable for incidental or consequential damages.

Aeromotive expressly retains the right to make changes and improvements in any product it manufactures and sells at any time. These changes and improvements may be made without notice at any time and without any obligation to change the catalogs or printed materials.

Aeromotive expressly retains the right to discontinue at any time and without notice any Aeromotive product that it manufactures or sells.

This warranty is limited and expressly limits any implied warranty to one year from the date of the original retail purchase on all Aeromotive products.

No person, party or corporate entity other than Aeromotive shall have the right to: determine whether or not this Limited Warranty is applicable to any Aeromotive product, authorize any action whatsoever under the terms and conditions of this Limited Warranty, assume any obligation or liability of any nature whatsoever on behalf of Aeromotive under the terms and conditions of this Limited Warranty.

This Limited Warranty covers only the product itself and not the cost of installation or removal.

This Limited Warranty is in lieu of and expressly excludes any and all other warranties, expressed or implied. This Limited Warranty gives you specific legal rights, and you may also have other rights which vary from state to state.